

KV901 BALL VALVE VE KV901-Y BALL VALVE



General Details

- Ball valves are brass; The actuator is designed for easy and quick installation.
- Made of durable and long-lasting material, it is resistant to abrasion. Actuator connections according to ISO 5211.

Technical Details

- Full transition
- Excellent sealing at low and high pressures
- Fast 90 degree opening operation
- No need maintenance

Thread

UNI EN 10226 thread.

Working Pressure

Refer to the table from PN 40 (1/4 ") to PN 25 (2" 1/2 PN25).

Temperature

-20 °C / 130 °C

Application

Ball valves are suitable for hot and cold water, air compressor, oil, hydrocarbon, non-corrosive fluid applications.

Refer to the chemical resistance table for different specific uses.

► KV901 BALL VALVE

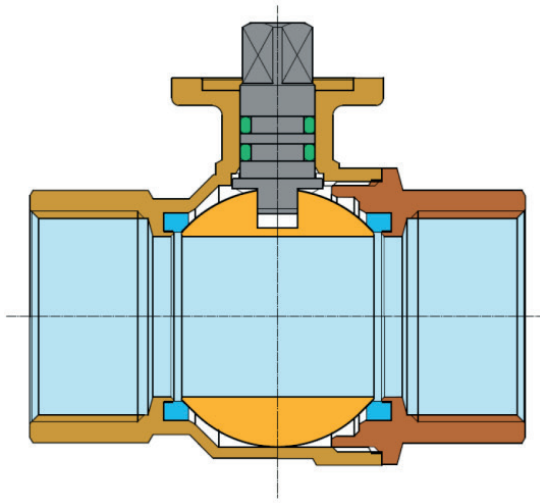

- BODY** 1 EN 12165
- MIDDLE PART** 2 EN 12165
- BALL** 3 EN 12165
- BALL GASKET** 4 P.T.F.E.
- SHAFT** 5 EN 12164
- STAMP** 6 P.T.F.E.
- BODY GASKET** 7 2 ELASTOMER O-RING

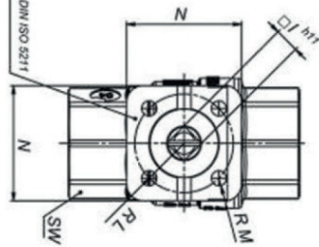
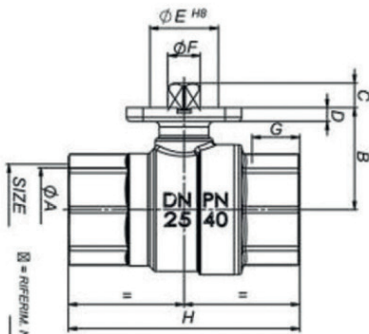

SIZE	1/4"	3/8"	1/2"	3/4"	1"	1" 1/4	1" 1/2	2"	2" 1/2	3"
DN	8	10	15	20	25	32	40	50	65	80
MAX TORK										
PN 0 T 25 °C	2,7 Nm	2,7 Nm	2,7 Nm	3,7 Nm	5,6 Nm	6,6 Nm	8 Nm	9,5 Nm	18 Nm	34 Nm
PN 16 T 25 °C	3 Nm	3 Nm	3 Nm	4,1 Nm	6,1 Nm	7,5 Nm	9,5 Nm	11,5 Nm	21 Nm	37 Nm
PN 25 T 25 °C	3 Nm	3 Nm	3 Nm	4,4 Nm	6,4 Nm	7,8 Nm	10,5 Nm	13 Nm	33 Nm	40 Nm
PN 40 T 25 °C	3,2 Nm	3,2 Nm	3,2 Nm	4,8 Nm	6,8 Nm	8,2 Nm	-	-	-	-
Kv H ₂ O	5,9	9,4	17	41	70	121	200	292	535	850

Observe the safety factor to be used with different actuators.

SIZE	1/4"	3/8"	1/2"	3/4"	1"	1" 1/2	2"	2" 1/2	3"
ØA pass./bore	10	10	15	20	25	40	48	61	78
B mm	29,4	29,4	29,4	33	37,2	53	64	82,75	94,5
C mm	9	9	9	9	9	11	11	14	15,5
D mm	5	5	5	5	5	5,5	6,5	10	11,5
ØE mm	25	25	25	25	25	30	30	55	55
F mm	10,8	10,8	10,8	10,8	10,8	13,9	13,9	20,9	26,9
G mm	15	15	15	16,3	19,1	21,4	25,7	30,2	33,3
H mm	61	61	61	69,5	84,5	110	130	161	183
I mm	9	9	9	9	9	11	11	14	14
L mm	18	18	18	18	18	21	21	35	35
M mm	2,75	2,75	2,75	2,75	2,75	2,75	2,75	4,5	4,5
N mm	37	37	37	37	42	42	48	68	68
O mm	F3	F3	F3	F3	F3	F4	F4	F7	F7
SW mm	25	25	25	31	38	55	68	83	98
Peao/Weight gr.	-	-	217	315	538	1159	1990	3606	5920

► KV901-Y KÜRESEL VANA

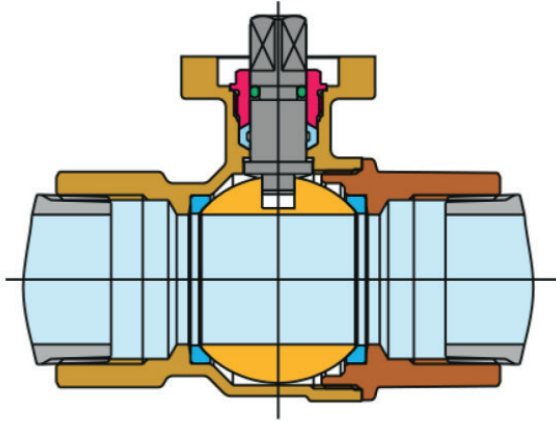

- 1 **BODY**
DW 617 N UNI EN 12165
- 2 **MIDDLE PART**
DW 617 N UNI EN 12165
- 3 **BALL**
DW 614 N UNI EN 12164
- 4 **BALL GASKET**
P.T.F.E.
- 5 **SHAFT**
DW 614 N UNI EN 12164
- 6 **O-RING**
ELASTOMETRO
- 7 **SEALING**
DW 614 N UNI EN 12164
- 8 **STAMP**
P.T.F.E.
- 9 **SHAFT GASKET**
P.T.F.E.

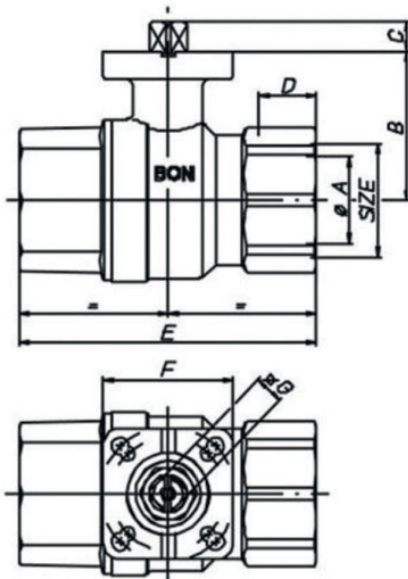

BODY	1/4"	3/8"	1/2"	3/4"	1"	1" 1/4	-	-	-
DN MAX (Bar)	40	40	40	40	40	40	-	-	-
TORK (Nm)	3,2	3,2	4,2	5,6	8,4	9,8	-	-	-

BODY	1/4"	3/8"	1/2"	3/4"	1"	1" 1/4	1" 1/2	2"	2" 1/2
PN 25	25	25	25	25	25	25	25	25	25
TORK (Nm)	2,6	2,6	4	5,2	7,8	9,1	13	25	38

BODY	1/4"	3/8"	1/2"	3/4"	1"	1" 1/4	1" 1/2	2"	2" 1/2
PN 25	16	16	16	16	16	16	16	16	16
TORK (Nm)	2,4	2,4	3,6	5	7,2	8,5	12	23	36

BODY	1/4"	3/8"	1/2"	3/4"	1"	1" 1/4	1" 1/2	2"	2" 1/2
PN 25	0	0	0	0	0	0	0	0	0
TORK (Nm)	2	2	3	4	6	7	10	20	32

Observe the safety factor to be used with different actuators.

SIZE	1/4"	3/8"	1/2"	3/4"	1"	1" 1/4	1" 1/2	2"	2" 1/2
ØA pass./bore	8	10	15	20	25	32	40	50	63
B mm	38	38	38	40,5	44	55	61,5	73	82,75
C mm	9	9	9	9	9	11	11	14	15,5
D mm	15	15	15	16,3	19,1	21,4	21,4	25,7	30,2
E mm	75	75	75	80	90	110	120	140	155
F mm	37	37	37	37	37	48	48	48	68
ØG mm	9	9	9	9	9	11	11	14	14
SW mm	26	26	26	32	41	50	55	70	83
ISO FLANGE	F3	F3	F3	F3	F3/F4	F4/F5	F4/F5	F5	F7
Peao/Weight gr.	412	390	342	463	705	1220	1650	2888	3285