

HIGH PERFORMANCE METAL SEATED BALL VALVES

Design & Features

- Valve Design According to ASME B16.34
- Anti-Blow-out Proof Stem Design & Anti-Static Device(Ball-Stem-Body)
- Face to Face According to ASME B16.10
- Pressure Tested in accordance with API 598
- Flange Dimension According to ASME B16.5
- Leakage Rate : ASME / FCI 70-2 Class V
- Cold Working Pressure : 19.0 Kgf/cm²
- End Connection : Raised Face Flange End
- Tn : Torque(N-m)
- Wg : Weight(Kg)

Standards

- Class : 150/300
- Design : ASME B16.34
- Face-to-Face : ASME B16.10
- Class 150 : 1/2"-5"
- Steel Casting : MSS SP-55
- Flange End Dimensions : ASME B16.5
- Inspection & Test acc. to API598

Specifications

- High Quality Investment Casting according to MSS SP-55
- Valve ball/seat surface hardening treatment provides valve life cycles
- API6FA, ISO10497 Fire safe certified product.
- Valve ball remains in close and tight contact with spring loaded ball seat for maximum sealing effects.
- Wave spring in 17-7 is our standard, Disc Spring design and Coil Spring design is upon request.
- Variety Ball/Seat selections to meet severe applications
- Adjustable stem packing
- Bi-directional flow path is upon request
- ISO5211 mounted pad for actuation
- 17-4ph stem is necessary for actuator installation
- Extended stem 100mm or 180mm is available
- Live loaded & blow-out proof stem design V ball in 30°,45°,60° for flow control application are available for options
- Machine-lapped ball and seat for tight contact between the two circular surfaces.
- Conforming to ANSI B16.104 / FCI 70-2 Class V leakage class; Class VI optional.

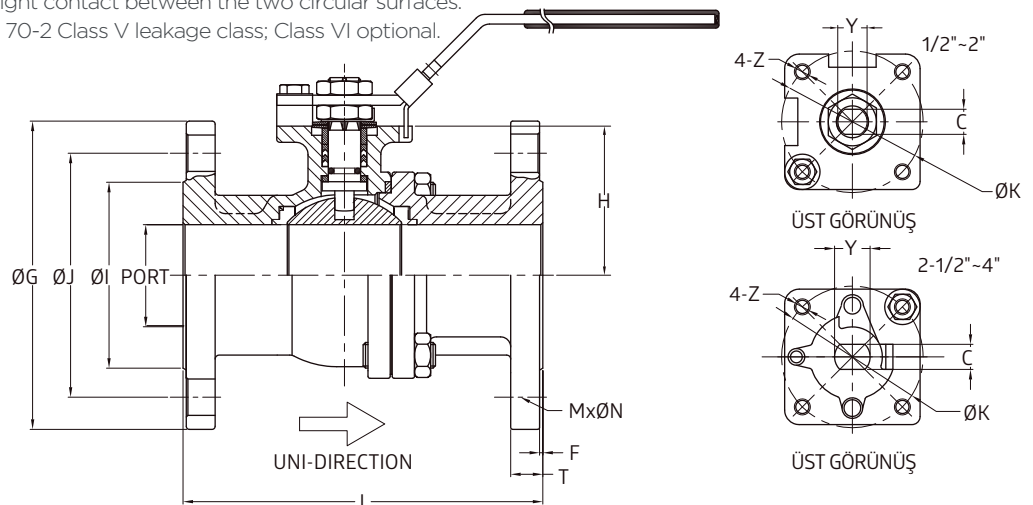

HIGH PERFORMANCE METAL SEATED BALL VALVES

Dimensions

Unit:mm

SIZE	PORT	L	H	ØG	ØJ	ØI	MxØN	T	F	C	Y	ØK	4-Z	Tn	Wg
DN15	1/2"	15.0	108.0	40.0	89.0	60.5	4x16.0	11.2	1.6	6.35	9.3	42.0	10-24UNC	18.0	1.6
DN20	3/4"	20.0	117.0	43.0	98.0	70.0	4x16.0	11.2	1.6	6.35	9.3	42.0	10-24UNC	25.0	2.2
DN25	1"	25.0	127.0	51.0	108.0	79.5	4x16.0	11.2	1.6	8.00	10.9	50.0	1/4"-20UNC	30.0	3.0
DN40	1-1/2"	38.0	165.0	70.0	127.0	98.5	4x16.0	14.3	1.6	9.50	15.7	70.0	5/16"-18UNC	45.0	6.0
DN50	2"	50.0	178.0	73.0	152.0	120.5	4x19.0	16.0	1.6	9.50	15.7	70.0	5/16"-18UNC	65.0	9.5
DN65	2-1/2"	65.0	190.0	73.0	178.0	139.5	4x19.0	17.5	1.6	17.00	28.0	70.0	1/2"-13UNC	80.0	15.0
DN80	3"	76.0	203.0	102.0	190.0	152.5	4x19.0	19.1	1.6	17.00	28.0	102.0	1/2"-13UNC	99.0	20.0
DN100	4"	101.0	229.0	114.0	229.0	190.5	8x19.0	23.9	1.6	17.00	28.0	102.0	1/2"-13UNC	131.0	32.0
DN125	5"	125.0	356.0	155.0	254.0	216.0	8x22.0	23.9	1.6	17.00	29.5	102.0	1/2"-13UNC	488.0	47.5

Exploded View

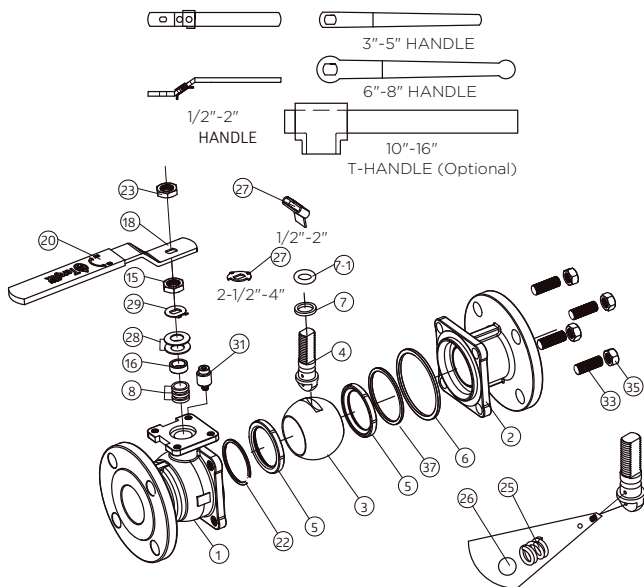

Body Pressure / Temperature Chart

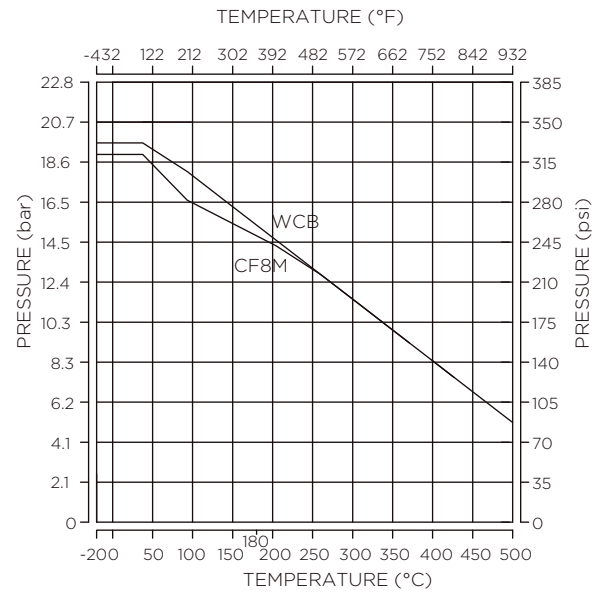

HIGH PERFORMANCE METAL SEATED BALL VALVES

Malzeme Listesi

VALVE OPTIONS		STAINLESS STEEL				CARBON STEEL			
		STANDARD		OPTIONAL		STANDARD		OPTIONAL	
		HARD CHROME	STELLITE SEAT	TUNGSTEN CARBIDE	CHROME CARBIDE	HARD CHROME	STELLITE SEAT	TUNGSTEN CARBIDE	CHROME CARBIDE
NO.	PART NAME	-29°C-350°C	-29°C-538°C	-29°C-400°C	-29°C-538°C	-29°C-350°C	-29°C-538°C	-29°C-400°C	-29°C-538°C
1	BODY	ASTM A351 Gr.CF8M				ASTM A216 Gr.WCB			
2	END CAP	ASTM A351 Gr.CF8M				ASTM A216 Gr.WCB			
3	BALL	ASTM A351 CF8M + HCr	ASTM A351 CF8M + STL	ASTM A351 CF8M + TC	ASTM A351 CF8M + CrC	ASTM A351 CF8M + HCr	ASTM A351 CF8M + STL	ASTM A351 CF8M + TC	ASTM A351 CF8M + CrC
4	STEM	17-4ph				17-4ph			
5	SEAT	SS316+STL	SS316+STL	SS316+TC	SS316+CrC	SS316+STL	SS316+STL	SS316+TC	SS316+CrC
6	BODY SEAL	GRAPHITE + SPIRALWOUND				GRAPHITE + SPIRALWOUND			
7	THRUST WASHER	GRAPHITE				GRAPHITE			
7-1	THRUST WASHER	STAINLESS				STAINLESS			
8	STEM PACKING	GRAPHITE				GRAPHITE			
15	GLAND BUSH	ASTM A276 Gr.304				ASTM A276 Gr.304			
16	STEM NUT	ASTM A276 Gr.304				ASTM A276 Gr.304			
18	HANDLE	ASTM A276 Gr.304				ASTM A276 Gr.304			
20	HANDLE COVER	PLASTIC				PLASTIC			
22	SPRING	INCONEL or 17-7				INCONEL or 17-7			
23	HANDLE NUT	ASTM A276 Gr.304				ASTM A276 Gr.304			
25	PLUNGER SPRING	ASTM A276 Gr.316				ASTM A276 Gr.316			
26	ANTI-STATIC BALL	ASTM A276 Gr.316				ASTM A276 Gr.316			
27	LOCKING PAD	ASTM A276 Gr.304				ASTM A276 Gr.304			
28	BELLEVILLE WASHER	SS420				SS420			
29	TAB WASHER	ASTM A276 Gr.304				ASTM A276 Gr.304			
31	STOP PIN	ASTM A276 Gr.304				ASTM A276 Gr.304			
33	BODY BOLT	ASTM A193 Gr.B8				ASTM A193 Gr.B7			
35	BOLT NUT	ASTM A194 Gr.8				ASTM A194 Gr.2H			
37	SEAT SEALS	GRAPHITE				GRAPHITE			